

# VPS9

IP 24c

Monteringsanvisning  
 Monteringsvejledning  
 Monteringsanvisning  
 Asennusohjeet

Montageanweisung  
 Installation instructions  
 Instrukcja montazu  
 Montavimo instrukcija

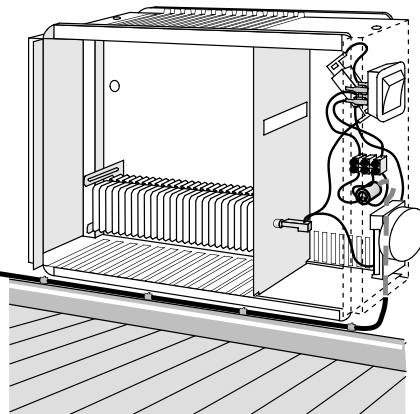
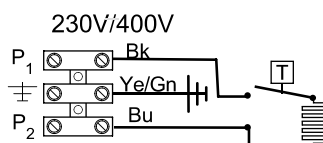
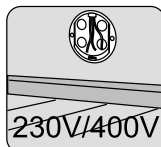
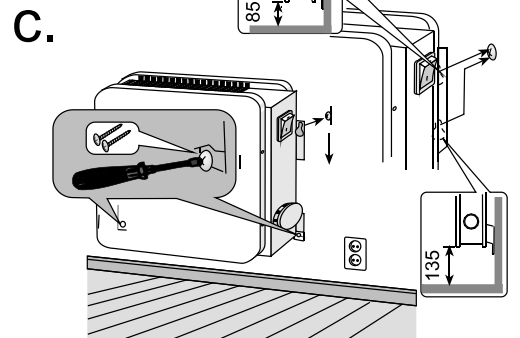
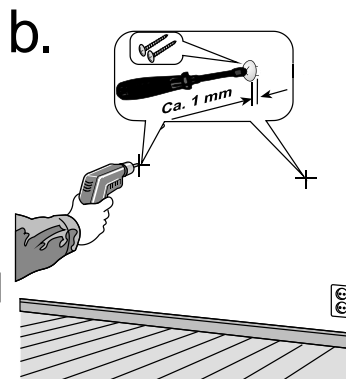
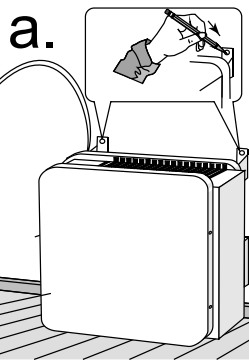
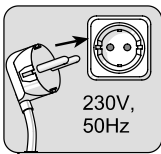
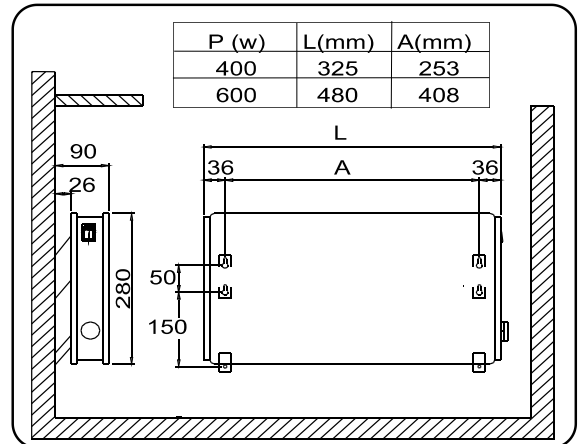
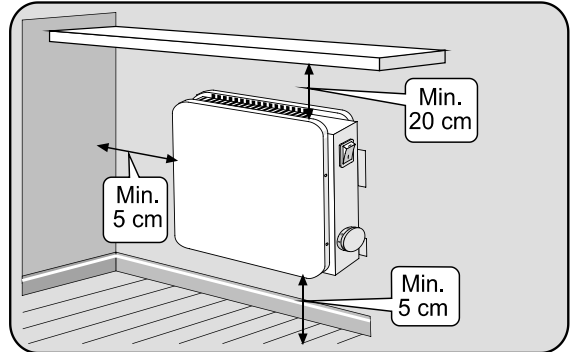
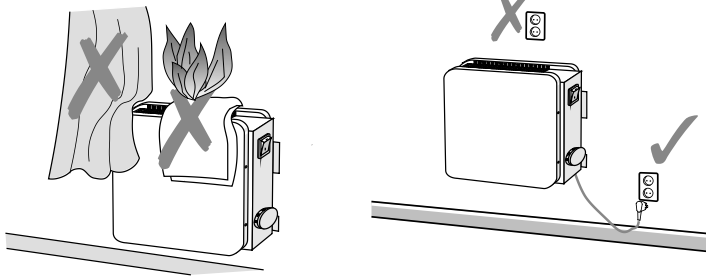
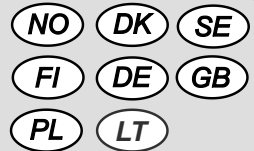

Elektrisk montasje må bare utføres av autorisert installatør.  
 Elektrisk montage må kun udføres af autoriseret el. installatør.

Elektrisk installation får endast utföras av behörig installatör.

Sähköasennukset saa suorittaa vain asennusoikeudet omaava asennusliike.

Anschluß darf nur durch Fachmann durchgeführt werden.

Electric installation must be carried out by an authorised electrician.

Podłączenie do sieci elektrycznej należy powierzyć elektryczniemu instalatorowi.

Instaliavimas ir pajungimas turi būti atliekamas sertifikuoto elektriko.

**Bruk  
 Brug  
 Användning  
 Käyttö  
 Bedienung  
 Use  
 Obsługa  
 Naudojimas**

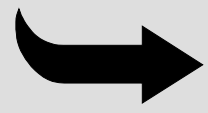

Art. nr. 62289 02/04

Ye/Gn	Gul/grønn	Gul/Grøn	Gul/Grön	Kelta/Vihreä	Gelb/Grün	Yellow/Green	Zółty/Zielony	Geltonas/Žalias
Bk	Sort	Sort	Svart	Musta	Schwarz	Black	Czarny	Juodas
Bu	Blå	Blå	Blå	Sininen	Blau	Blue	Niebieski	Mėlynas

# VPS9

**Bruksanvisning  
Brugsanvisning  
Bruksanvisning  
Käyttöohjeet**

**Bedienungsanleitung  
Instruction for use  
Instrukcja obsługi  
Naudojimosi instrukcija**

**NO** **DK** **SE**  
**FI** **DE** **GB**  
**PL** **LT**

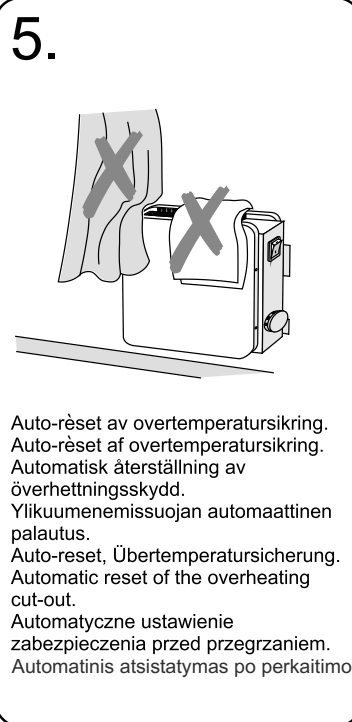
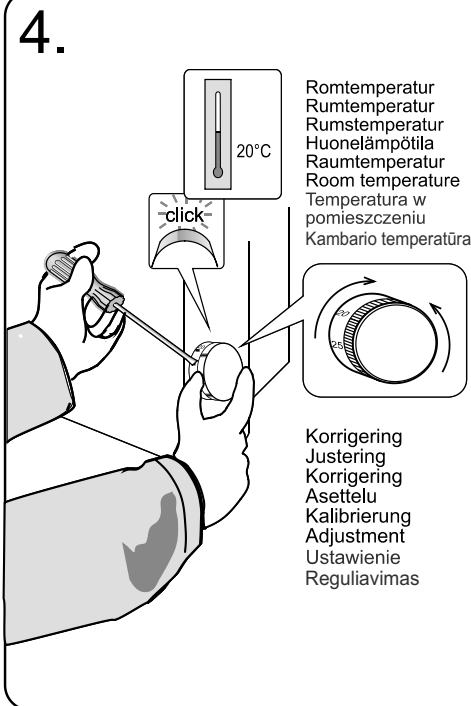
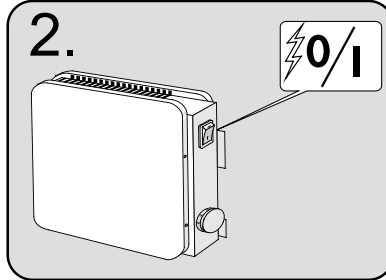
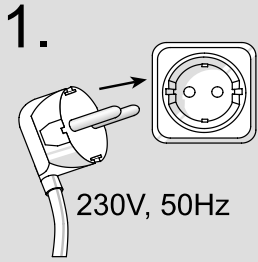

**NO**

Service: ADAX AS, 3060 SVELVIK, tlf. 33 771792.  
NB! Ta vare på kvitteringen for dokumentasjon av kjøpsdato.

**DK**

Service: Appliance A/S, Korskildeeng 5, DK-2670 Greve Strand, tel. +45 43410060.  
NB! Husk kvittering for købsdato.

**SE**

Service: El & Digital service AB, Ringvägen 17 S-10273 STOCKHOLM, tel. 08 845180.  
OBS! Faktura/kvitto gäller som garantibevis.

**FI**

Huolto: Elektroskandia Oy, Varastokatu 9, 05800 HYVINKÄÄ, puh. 010 509311.  
Aronen J & K Oy, Ostuuskunnantie 54A, 00660 Helsinki, puh. 09 724 7772.  
Huom! Säilytä kuitti todistuksena ostopäivästä.

**DE**

Service: ADAX AS, NO-3060 SVELVIK, NORWEGEN, Tlf. +47 33 771792.  
NB! Quittung zum Nachweis des Kaufdatums aufheben.

**GB**

Service: ADAX AS, NO-3060 SVELVIK, NORWAY, phone +47 33 771792.  
NB! Retain the receipt as proof of date of purchase.

**PL**

Serwis: Elektra, ul. Marynarska 14, 02-674 Warszawa, tel. (+22) 8433282  
Prosimy zachowac rachunek zakupu oraz karte gwarancyjna.

**LT**

Aptarnavimas: UAB Adax, Paliūniškio g. 7a, LT-35113 Panevėžys, Lietuva, tel.: +370 45 578311  
DĖMESIO! - Saugokite kasos kvitą, kaip pirkimo datos įrodymą.

[www.adax.no](http://www.adax.no)

**ADAX**

**Montering  
Montering  
Montering  
Asennus  
Montage  
Installation  
Instalacja  
Montavimas**



## Atitikties deklaracija

Mes patvirtiname, kad mūsų gaminama produkcija atitinka sekančius standartus:  
EN 60 335-1 (1988)+A2+A5+A6+A51+A52+A53+A54, EN 60 335-2-30 (1992), EN 55014 (1993), EN 60555-2/-3 (1991),  
EN 50082-1 (1992) pagal Direktyvas 73/23/EEC, 93/68/EEC, 89/336/EEC.

Adax Fabrikker A/S, SVELVIK, NORWAY Gruodis 1996.

*Tor Age Kverne*

Tor Age Kverne